

## Redetermination by Neutron Diffraction of the Structure of Manganese Acetate Tetrahydrate (MAT)

By D. TRANQUI,\* P. BURLET,† A. FILHOL AND M. THOMAS

*Institut Laue–Langevin, 156X Centre de Tri, 38042 Grenoble Cédex, France*

(Received 27 September 1976; accepted 12 October 1976)

A neutron diffraction study of the crystal structure of manganese acetate tetrahydrate  $\text{Mn}(\text{CH}_3\text{COO})_2 \cdot 4\text{H}_2\text{O}$  is reported. The results of an earlier X-ray determination of this structure are confirmed and, in addition, the positions of H atoms are determined with a final  $R$  of 0.05 for 1401 independent reflexions. The two-dimensional character of this structure is clearly shown by the fact that the cohesion between planes containing the Mn atoms and acetate groups is maintained by hydrogen bridges involving the H atoms of water molecules only.

### Introduction

Transition-metal acetates form a class of compounds which have been the subject of considerable study in the last 20 years from the structural and magnetic points of view. The structures of  $\text{Co}^{\text{II}}$ ,  $\text{Ni}^{\text{II}}$  and  $\text{Zn}^{\text{II}}$  acetates have been determined by van Niekerk & Shoening (1953). In determining the structure of  $\text{Cu}^{\text{II}}$  acetate monohydrate, these authors found a very short Cu–Cu distance, 2.65 Å (in metallic copper, the shortest Cu–Cu separation is 2.556 Å). The existence of such a short distance could indicate that a mechanism of direct magnetic exchange interaction between the  $\text{Cu}^{2+}$  ions in the crystal must be taken into account.  $\text{Cr}^{\text{II}}$  and  $\text{Rh}^{\text{II}}$  acetate monohydrates are isostructural with the  $\text{Cu}^{\text{II}}$  acetate monohydrate.

As a result of the interest aroused by the dinuclear structure of  $\text{Cu}^{\text{II}}$  acetate monohydrate, Brown & Chidambaram (1973) determined by neutron diffraction the atomic positions of the heavy atoms as well as the coordinates of the H atoms.

More recently, in connexion with the study of the magnetic structures of transition-metal carboxylates, Bertaut, Tranqui, Burlet, Burlet, Thomas & Moreau (1974) determined the crystalline structure of  $\text{Mn}^{\text{II}}$  acetate tetrahydrate (MAT)  $[\text{Mn}(\text{CH}_3\text{COO})_2 \cdot 4\text{H}_2\text{O}]$  from X-ray data. They found that this salt crystallizes in the monoclinic system with the space group  $P2_1/c$ . The unit cell contains six formula units and measures:  $a = 11.10 \pm 0.01$ ,  $b = 17.51 \pm 0.02$ ,  $c = 9.09 \pm 0.01$  Å,  $\beta = 118.62 \pm 0.05^\circ$ .

The Mn atoms lie in the  $bc$  plane or very near it ( $x = 0.02$ ). Within these planes they are connected by

Mn–O–Mn bonds and by acetate bridges. The two-dimensional character of this structure arises because the only atoms which are not very close to the  $bc$  planes ( $d_{100} = 9.74$  Å) are those of the intercalated water molecules. Therefore, the hydrogen bonds involving the atoms of these water molecules can be expected to play an important role in the plane cohesion.

A low-temperature neutron-diffraction study made possible the determination of the magnetic structure of MAT (Burlet, Burlet & Bertaut, 1974). It was found that in zero field it is antiferromagnetic and becomes ferrimagnetic in an applied field. In zero magnetic field the antiferromagnetic structure exhibits an antiparallel coupling between the moments of two contiguous (100) planes. The dipole interaction is not enough to explain this coupling; therefore, one must consider that an exchange interaction exists between two planes of Mn ions.

The strength of this interaction can be estimated as being very weak ( $\approx 10^{-3}$  K) from the observed magnetization threshold values (Friedberg & Schmidt, 1969) or from magnetic neutron-diffraction measurements. Therefore, the precise location of the H atoms is necessary for further discussion of the magnetic behaviour of MAT in addition to the structural and chemical interests.

The X-ray diffraction measurements on a single crystal did not enable Bertaut *et al.* (1974) to position the H atoms, so the neutron diffraction study which we report here was performed to fill this gap.

### I. Experiment

The MAT crystals were obtained by slow evaporation of saturated aqueous solutions. They crystallize as transparent pink lozenge-shaped plates, are easily cleaved along the (100) plane, are very brittle, and deteriorate quite rapidly.

\* Laboratoire des Rayons X, CNRS, BP 166, 38042 Grenoble Cédex, France.

† Laboratoire de Diffraction Neutronique DRF-CEN Grenoble, BP 85, 38042 Grenoble Cédex, France.

Despite these unfavourable conditions we were able to isolate a good-quality crystal which, because of its fragility, was used in its natural uncut form. Fig. 1 shows its shape and dimensions.

The crystal was glued to a cadmium pin and fixed on a goniometer head. It was tested and oriented with the aid of an X-ray precession camera and finally placed on the four-circle neutron diffractometer D8 at the Laue-Langevin Institute (Filhol, Thomas & Vicat, 1974; Thomas & Filhol, 1974). The  $b$  axis was nearly parallel to the  $\varphi$  axis of the diffractometer. The wavelength used was 1.217 Å [monochromator Cu (200) in transmission]. The divergence of the monochromatic beam was 60' and in these conditions the flux at the sample was  $2 \times 10^7$  n cm<sup>-2</sup>.

The intensity measurements were carried out by the  $\theta/2\theta$  scan mode. The angular scan range was calculated for each reflexion from the experimental resolution curve, the duration of counting being determined by a short preliminary count on the maximum of each Bragg peak. During the experiment the standard reflexions, which were measured periodically, remained constant within a dispersion which was less than three times the standard deviation. 1401 independent reflexions were measured in the  $2\theta$  angular domain of 0 to 80°.

The harmonic  $\lambda/2$  contamination was evaluated by measuring some systematically extinct reflexions corresponding to strong  $2h, 2k, 2l$  reflexions. Since this contamination was about 0.5%, it was decided to neglect it.

The data reduction program written by Filhol was used to convert the observed intensities into structure factors. An absorption correction was applied. The ab-

sorption coefficient  $\mu$  was experimentally determined by measuring the attenuation by a MAT crystal (3 mm thick), placed either in front of the sample or in front of the counter, of strong reflexions from a test crystal. The average value of  $\mu$  thus determined was  $2.43 \pm 0.1$  cm<sup>-1</sup>.

## II. Refinement of the structure and determination of the hydrogen positions

A conventional refinement procedure was used. The initial positional parameters of the heavy atoms (Mn, O, C) were those given by Bertaut *et al.* (1974). The neutron scattering amplitudes used were: Mn -0.36, C 0.66, O 0.577, H  $-0.378 \times 10^{-12}$  cm. A Fourier difference map at this stage made possible the ready location of the 12 H atoms of the six water molecules, whereas the 9 H atoms of the three CH<sub>3</sub> groups gave poorly defined peaks. An improvement of the structural refinement was obtained by including the 20 heavy atoms and the 21 H atoms at the same time. The thermal parameters of the H atoms were first refined isotropically and then converted to anisotropic. The final  $R$  was 0.06. The introduction of the secondary extinction correction reduced  $R$  to 0.05. The positional parameters and the anisotropic thermal factors are given in Table 1.\* Table 2 contains the interatomic distances and angles.

## III. Description of the structure

### III.1. Acetic groups and coordination of the Mn<sup>2+</sup> atoms

There are three independent acetic bridges in the crystal. The three corresponding distances C(1)-C(2), C(3)-C(4) and C(5)-C(6) of 1.515 (6), † 1.498 (8) and 1.520 (5) Å are practically equal. The same is not true for the C-O bonds; in the first acetate group C(1)H<sub>3</sub>-C(2)O<sub>2</sub> the two C-O distances are quite different. O(1), which is coordinated at the same time to Mn<sup>2+</sup>(1) and Mn<sup>2+</sup>(2), has a C(1)-O(1) distance longer [1.286 (6) Å] than O(2), which is coordinated only to Mn<sup>2+</sup>(2) [C(1)-O(2) = 1.246 (6) Å]. The O atoms O(3), O(4), O(5) and O(6) of the last two acetate groups, all of which form long H...O bonds with the water H atoms, have practically equal C-O distances [1.255 (7) to 1.262 (6) Å]. The angles O(3)-C(3)-O(4) and O(5)-C(5)-O(6) are 125.0 (5) and

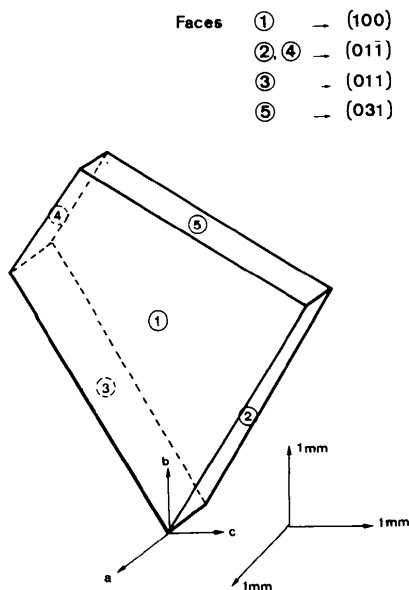

Fig. 1. Shape and dimensions of the sample.

\* A list of structure factors has been deposited with the British Library Lending Division as Supplementary Publication No. SUP 32235 (7 pp.). Copies may be obtained through The Executive Secretary, International Union of Crystallography, 13 White Friars, Chester CH1 1NZ, England.

† In this paper, figures in parentheses are the standard deviations.

Table 1. *Positional parameters* ( $\times 10^4$ ) *and anisotropic thermal parameters* ( $\times 10^4$ )
$$T = \exp[-2\pi^2(h^2 a^{*2} U_{11} + k^2 b^{*2} U_{22} + l^2 c^{*2} U_{33} + 2hka^* b^* U_{12} + 2hla^* c^* U_{13} + 2klb^* c^* U_{23})].$$

	<i>x</i>	<i>y</i>	<i>z</i>	<i>U</i> <sub>11</sub>	<i>U</i> <sub>22</sub>	<i>U</i> <sub>33</sub>	<i>U</i> <sub>12</sub>	<i>U</i> <sub>13</sub>	<i>U</i> <sub>23</sub>
Mn(1)	0 (0)	0 (0)	0 (0)	122	115	96	2	134	-29
Mn(2)	201 (6)	2982 (4)	4321 (7)	162	117	151	-17	486	-66
C(1)	134 (3)	1414 (2)	2391 (4)	252	110	165	12	136	-1
C(2)	27 (5)	868 (2)	3609 (5)	841	156	301	3	227	20
C(3)	2193 (4)	4201 (2)	4124 (4)	133	208	276	-5	21	5
C(4)	3394 (5)	4368 (3)	3850 (8)	433	311	1131	-123	16	-154
C(5)	8013 (4)	4110 (2)	1594 (4)	201	148	177	8	58	-5
C(6)	6785 (4)	4209 (3)	-136 (5)	295	410	319	169	-86	-93
O(1)	98 (4)	1156 (2)	1048 (5)	302	43	211	-1	271	-33
O(2)	241 (5)	2109 (3)	2689 (5)	435	181	221	-33	207	-78
O(3)	1745 (5)	3529 (3)	3884 (6)	326	237	461	-86	190	-26
O(4)	1720 (5)	4740 (3)	4594 (6)	348	236	452	15	113	-1
O(5)	8361 (5)	4668 (3)	2583 (5)	336	222	233	28	648	-21
O(6)	8634 (5)	3482 (3)	1954 (5)	368	248	224	70	123	-8
OW(7)	2055 (5)	2549 (3)	1475 (5)	339	366	268	-124	186	-112
OW(8)	8365 (4)	2461 (3)	4296 (5)	302	250	244	-38	67	50
OW(9)	4292 (5)	3179 (3)	1286 (6)	334	551	388	13	210	77
OW(10)	6124 (5)	1972 (4)	1497 (6)	358	776	341	-92	55	-235
OW(11)	6713 (5)	3776 (3)	4124 (6)	363	338	488	-33	217	-23
OW(12)	3330 (6)	1060 (3)	3307 (7)	418	377	405	-52	-52	-109
H(1)	-744 (35)	568 (19)	3134 (24)	3203	2623	1016	-2329	1052	-253
H(2)	74 (19)	1135 (7)	4599 (15)	2649	484	772	-281	1228	-105
H(3)	596 (34)	446 (12)	3838 (37)	3848	1157	2954	1599	3050	1598
H(4)	2898 (11)	1416 (6)	2518 (12)	764	630	580	-212	125	-24
H(5)	2766 (10)	612 (6)	2927 (13)	480	750	726	-103	117	-61
H(6)	4275 (18)	4209 (18)	4893 (39)	691	2551	2783	288	901	1197
H(7)	3538 (16)	4947 (7)	3728 (25)	1214	457	2515	-257	1495	-186
H(8)	3350 (26)	4097 (13)	2877 (34)	2186	1877	2694	-1189	2305	-1356
H(9)	6221 (9)	1739 (5)	607 (10)	568	573	352	-104	149	-123
H(10)	5464 (12)	2296 (7)	1175 (13)	826	749	603	-225	300	-99
H(11)	6290 (24)	1220 (12)	4460 (28)	1361	1194	1237	65	-789	21
H(12)	6193 (22)	368 (14)	4793 (22)	1411	2064	989	-1345	-536	625
H(13)	7033 (20)	720 (23)	4038 (20)	1106	4016	484	-95	24	-1007
H(14)	7129 (10)	4269 (6)	4379 (13)	552	480	785	-125	317	49
H(15)	7386 (10)	3433 (7)	4223 (13)	475	933	684	-168	274	-59
H(16)	8461 (8)	2149 (5)	5276 (9)	442	426	308	-19	184	98
H(17)	7642 (8)	2254 (5)	3307 (10)	501	494	471	-36	280	36
H(18)	3944 (10)	3495 (6)	201 (12)	594	712	532	27	253	45
H(19)	4969 (11)	3434 (6)	2105 (13)	836	660	806	49	576	1
H(20)	1935 (8)	2828 (5)	2345 (10)	571	541	401	-33	329	-195
H(21)	2804 (8)	2776 (5)	1370 (10)	478	523	407	-85	232	-15

123.7 (4)<sup>o</sup> respectively. These values are noticeably higher than those corresponding to the angle O(1)–C(1)–O(2) [120.6 (4)<sup>o</sup>] of the first acetic bridge.

Each Mn atom is surrounded by six O atoms: four from the CH<sub>3</sub>–CO<sub>2</sub> groups and two from the water molecules H<sub>2</sub>O(7) and H<sub>2</sub>O(8). The octahedron surrounding the Mn<sup>2+</sup>(1) cation is centrosymmetric and is slightly elongated in the O–Mn–O direction parallel to the (100) plane [Mn–O = 2.229 (4), 2.158 (4), 2.161 (4) Å]. The polyhedron surrounding the Mn<sup>2+</sup>(2) cation is quite distorted [Mn–O = 2.153 (8) up to 2.256 (7) Å].

These octahedra are connected in the (100) plane by their common acetate ligands to complete a two-dimensional network. The bonding between these atoms is reinforced by hydrogen bridges which are described in detail below.

### III.2. Description of the hydrogen bonds

*Study of the methyl CH<sub>3</sub> groups.* First it should be noted that as expected the H atoms of the methyl groups do not establish any hydrogen bonds with any other atom in the crystal. The Fourier peaks corresponding to these H atoms are rather diffuse and the thermal factors obtained by least-squares refinement (in the harmonic and independent vibration model) are relatively large. This phenomenon is characteristic of torsional oscillations of the CH<sub>3</sub> groups around the C–C axis and therefore the lengths of the methyl C–H bonds appear shorter than they actually are (Cruickshank, 1956; Busing & Levy, 1964). The uncorrected C–H distances corresponding to the CH<sub>3</sub> group vary between 0.90 and 1.05 Å (Table 2), *i.e.* 0.97 Å is the mean bond length. This value is considerably less than

Table 2. Bond lengths (Å) and angles (°)

(a) Coordination octahedra of Mn(1) and Mn(2)			
Mn(1)—O(1)	2.229 (4)	Mn(2)—O(3)	2.163 (9)
Mn(1)—O(4)	2.161 (6)	Mn(2)—O(6)	2.202 (9)
Mn(1)—O(5)	2.158 (4)	Mn(2)—O $\mathcal{W}$ (7)	2.256 (7)
Mn(2)—O(1)	2.226 (8)	Mn(2)—C $\mathcal{W}$ (8)	2.227 (9)
Mn(2)—O(2)	2.153 (8)		
O(1)—Mn(1)—O(4)	89.3 (2)	O(2)—Mn(2)—O(6)	83.0 (3)
O(1)—Mn(1)—O(5)	88.1 (2)	O(2)—Mn(2)—O $\mathcal{W}$ (7)	89.5 (3)
O(4)—Mn(1)—O(5)	81.3 (2)	O(2)—Mn(2)—O $\mathcal{W}$ (8)	91.2 (3)
O(1)—Mn(2)—O(2)	177.0 (4)	O(3)—Mn(2)—O(6)	88.1 (3)
O(1)—Mn(2)—O(3)	98.0 (3)	O(3)—Mn(2)—O $\mathcal{W}$ (7)	82.6 (3)
O(1)—Mn(2)—O(6)	97.7 (3)	O(3)—Mn(2)—O $\mathcal{W}$ (8)	169.9 (3)
O(1)—Mn(2)—O $\mathcal{W}$ (7)	90.2 (3)	O(6)—Mn(2)—O $\mathcal{W}$ (7)	168.6 (5)
O(1)—Mn(2)—O $\mathcal{W}$ (8)	86.1 (4)	O(6)—Mn(2)—O $\mathcal{W}$ (8)	82.2 (3)
O(2)—Mn(2)—O(3)	84.9 (4)	O $\mathcal{W}$ (7)—Mn(2)—O $\mathcal{W}$ (8)	106.8 (4)
(b) Acetic groups			
C(1)—C(2)	1.515 (6)	C(2)—H(1)	0.917 (32)
C(3)—C(4)	1.498 (8)	C(2)—H(2)	0.996 (16)
C(5)—C(6)	1.520 (5)	C(2)—H(3)	0.931 (28)
C(1)—O(1)	1.286 (6)	C(4)—H(4)	1.023 (22)
C(2)—O(2)	1.246 (6)	C(4)—H(5)	1.046 (14)
C(3)—O(3)	1.262 (6)	C(4)—H(6)	0.987 (32)
C(3)—O(4)	1.255 (7)	C(6)—H(7)	0.901 (20)
C(5)—O(6)	1.262 (6)	C(6)—H(8)	0.977 (25)
C(5)—O(5)	1.261 (6)	C(6)—H(9)	0.923 (24)
O(1)—C(1)—O(2)	120.6 (4)	H(4)—C(4)—H(6)	109.0 (3)
H(1)—C(2)—H(2)	109.0 (3)	H(5)—C(4)—H(6)	109.0 (3)
H(1)—C(2)—H(3)	92.0 (3)	O(6)—C(5)—O(5)	123.7 (4)
H(2)—C(2)—H(3)	116.0 (3)	H(7)—C(6)—H(9)	111.0 (2)
O(3)—C(3)—O(4)	125.0 (5)	H(7)—C(6)—H(9)	98.0 (3)
H(4)—C(4)—H(5)	104.0 (2)	H(8)—C(6)—H(9)	107.0 (3)
(c) Water molecules			
O $\mathcal{W}$ (7)—H(20)	0.992 (11)	O $\mathcal{W}$ (12)—H(10)	0.899 (11)
O $\mathcal{W}$ (7)—H(21)	0.968 (12)	O $\mathcal{W}$ (12)—H(11)	0.964 (12)
O $\mathcal{W}$ (8)—H(16)	1.009 (10)	O $\mathcal{W}$ (10)—H(12)	0.960 (12)
O $\mathcal{W}$ (8)—H(17)	0.945 (8)	O $\mathcal{W}$ (10)—H(13)	0.862 (13)
O $\mathcal{W}$ (9)—H(18)	1.034 (11)	O $\mathcal{W}$ (11)—H(14)	0.959 (11)
O $\mathcal{W}$ (9)—H(19)	0.886 (10)	O $\mathcal{W}$ (11)—H(15)	0.930 (13)
H(20)—O $\mathcal{W}$ (7)—H(21)	108.9 (9)	H(12)—O $\mathcal{W}$ (10)—H(13)	114.7 (10)
H(16)—O $\mathcal{W}$ (8)—H(17)	108.2 (9)	H(14)—O $\mathcal{W}$ (11)—H(15)	107.0 (11)
H(18)—O $\mathcal{W}$ (9)—H(19)	107.9 (10)	H(10)—O $\mathcal{W}$ (12)—H(11)	106.3 (9)

that determined by Bartell, Kuchitsu & Denevi (1961) on the basis of electron diffraction data on gaseous methane.

*Study of the water molecules (hydrogen bonds and crystalline cohesion).* The O—H distances correspond-

ing to the water molecules vary between 0.862 (13) and 1.034 (11) Å (uncorrected 'riding' model values). As was first noted by Nakamoto, Margoshes & Rundle (1955) this spread is due to the presence of O—H...O bonds of unequal strengths: in general the O—H distance decreases when O—H...O increases. For example, to the strong bond O $\mathcal{W}$ (9)—H(18)...O $\mathcal{W}$ (12) (2.74 Å) corresponds the bond length O(10)—H(13) = 1.03 Å while to the weak bond O $\mathcal{W}$ (10)—H(13)...O $\mathcal{W}$ (9) (2.88 Å) corresponds O(10)—H(13) = 0.86 Å.

A study of the O—H...O distances (Table 3) shows that: (1) hydrogen bonds are generally strong when the two bonded O atoms are water O atoms, while they are weak if one of the O atoms belongs to the acetic group (we shall call these 'mixed hydrogen bonds'); (2) all the water H atoms participate in the formation of hydrogen bridges.

In accordance with the classification of Hamilton & Ibers (1968) we can distinguish here three different types of links: (1) In the water molecules H<sub>2</sub>O(10) and H<sub>2</sub>O(12) the single hydrogen bond [O $\mathcal{W}$ (8)—H...O $\mathcal{W}$ (10) or O $\mathcal{W}$ (7)—H...O $\mathcal{W}$ (12)] follows the line bisecting the two free electron doublets of O $\mathcal{W}$ (10) or O $\mathcal{W}$ (12). This case is classified as type *F*, class 1. (2) The hydrogen bonds in H<sub>2</sub>O(9) and H<sub>2</sub>O(11) belong to class 2, type *E* with two O...H bonds following the axes of the two free doublets:

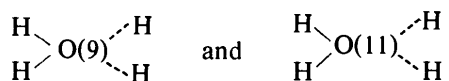

(3) The hydrogen bonds of H<sub>2</sub>O(8) and H<sub>2</sub>O(7) are of class 2, type *F* with two bonds O...Mn<sup>2+</sup> and O...H following the two axes of the electron doublets:

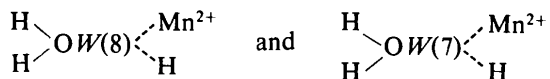

The angles H—O $\mathcal{W}$ —H of the six H<sub>2</sub>O are all more open than the value (104.5°) determined by Benedict, Gailar & Phylar (1956) in water vapour. The angles in H<sub>2</sub>O(7) and H<sub>2</sub>O(8) coordinated to Mn<sup>2+</sup>(2) are 108.9

Table 3. Hydrogen-bond distances (Å) and angles (°)

O—H...O	O—H	H...O	O...O	O—H...O
O $\mathcal{W}$ (12)—H(10)...O $\mathcal{W}$ (7)	0.899 (11)	2.215 (11)	3.065 (7)	157.6 (10)
O $\mathcal{W}$ (12)—H(11)...O(5)	0.964 (12)	1.997 (12)	2.957 (7)	173.3 (12)
O $\mathcal{W}$ (10)—H(12)...O $\mathcal{W}$ (11)	0.960 (12)	1.909 (12)	2.860 (9)	170.4 (8)
O $\mathcal{W}$ (10)—H(13)...O $\mathcal{W}$ (9)	0.861 (13)	2.061 (14)	2.884 (9)	159.5 (10)
O $\mathcal{W}$ (11)—H(14)...O(4)	0.959 (10)	2.099 (10)	3.046 (7)	168.8 (9)
O $\mathcal{W}$ (11)—H(15)...O $\mathcal{W}$ (8)	0.930 (13)	2.012 (13)	2.910 (7)	162.0 (10)
O $\mathcal{W}$ (8)—H(16)...O(5)	1.009 (10)	1.822 (10)	2.910 (7)	175.5 (8)
O $\mathcal{W}$ (8)—H(17)...O $\mathcal{W}$ (10)	0.945 (8)	1.773 (8)	2.710 (6)	171.0 (10)
O $\mathcal{W}$ (9)—H(18)...O $\mathcal{W}$ (12)	1.034 (11)	1.709 (11)	2.740 (7)	174.6 (10)
O $\mathcal{W}$ (9)—H(19)...O $\mathcal{W}$ (11)	0.886 (10)	2.019 (10)	2.889 (6)	166.7 (10)
O $\mathcal{W}$ (7)—H(20)...O(3)	0.992 (11)	1.952 (11)	2.916 (7)	170.4 (9)
O $\mathcal{W}$ (7)—H(21)...O $\mathcal{W}$ (9)	0.968 (11)	1.834 (12)	2.800 (8)	176.7 (7)

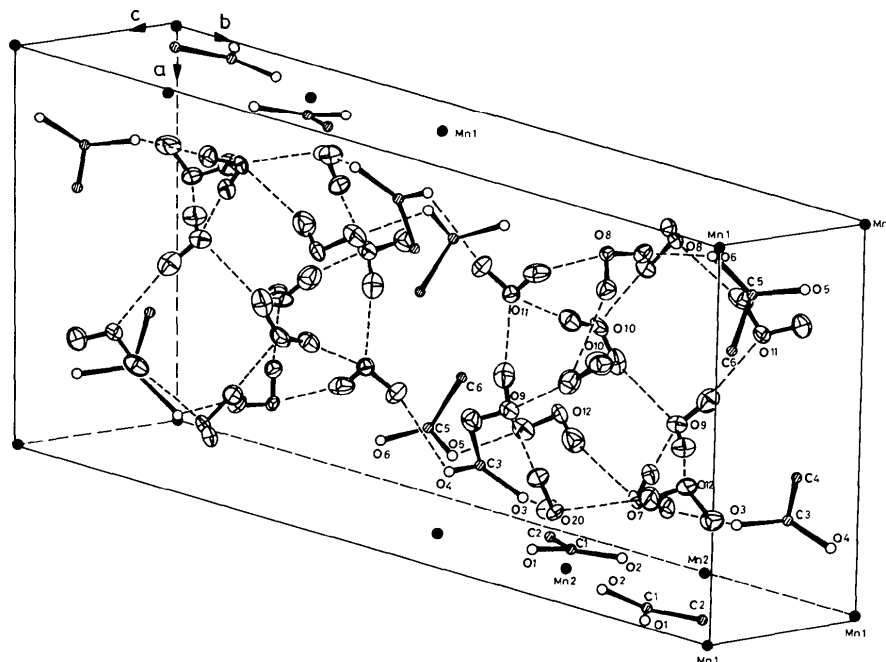

Fig. 2. ORTEP plot of the structure showing the network of hydrogen bonds. The hydrogen atoms of the acetic groups are not represented.

and  $108.2^\circ$  respectively. The increase found in these angles is due to the coupling of the  $2p\pi$ -orbital of the water molecule with the octahedron orbitals of the  $Mn^{2+}$  cation. The hybridization in the plane H—O—H would then be close to the  $sp^2$  mode, while the increase in the angles in  $H_2O(9)$ ,  $H_2O(10)$ ,  $H_2O(11)$  and  $H_2O(12)$  is due solely to the formation of the hydrogen bonds.

Fig. 2 shows the structure with its network of hydrogen bridges seen along *b*. The crystalline cohesion is ensured by the three-dimensional network of hydrogen links. The cohesion in the (100) plane is reinforced by 'mixed' hydrogen bonds, while between these planes it is maintained only by a network of strong hydrogen bridges between the six water molecules.

#### References

- BARTELL, L. S., KUCHITSU, K. & DENEVI, R. J. (1961). *J. Chem. Phys.* **35**, 1211–1218.
- BENEDICT, W. S., GAILAR, N. & PHYLER, E. K. (1956). *J. Chem. Phys.* **24**, 1139–1165.
- BERTAUT, E. F., TRANQUI, D., BURLET, P., BURLET, P., THOMAS, M. & MOREAU, J. M. (1974). *Acta Cryst.* **B30**, 2234–2236.
- BROWN, G. M. & CHIDAMBARAM, R. (1973). *Acta Cryst.* **B29**, 2393–2403.
- BURLET, P., BURLET, P. & BERTAUT, E. F. (1974) *Solid State Commun.* **14**, 655–668.
- BUSING, W. R. & LEVY, H. A. (1964). *Acta Cryst.* **17**, 142–146.
- CRUICKSHANK, D. W. J. (1956). *Acta Cryst.* **9**, 757–758.
- FILHOL, A., THOMAS, M. & VICAT, J. (1974). *Report on the Present Status of the D8 Diffractometer*. Internal Report 74T223T, Institut Laue–Langevin.
- FRIEDBERG, S. A. & SCHMIDT, V. A. (1969). *Phys. Rev.* **188**, 809–812.
- HAMILTON, W. C. & IBERS, J. A. (1968). *Hydrogen Bonding in Solids*, p. 206. New York, Amsterdam: Benjamin.
- NAKAMOTO, K., MARGOSHES, M. & RUNDLE, R. E. (1955). *J. Amer. Chem. Soc.* **77**, 6480.
- NIEKERK, J. N. VAN & SHOENING, F. R. L. (1953). *Acta Cryst.* **6**, 227–232.
- THOMAS, M. & FILHOL, A. (1974). *Optimisation des Conditions de Mesure pour les Diffractomètres Quatre Cercles D8 et D9*. Internal Report 74T104S. Institut Laue–Langevin.